

---

# LS8695AX / PLS8695 Ribbon Line Array System Assembly Guide



**SUPERIOR LISTENING SYSTEMS**  
AUDIO CLARITY REDEFINED



**SUPERIOR LISTENING SYSTEMS**  
AUDIO CLARITY REDEFINED

## LS8695AX / PLS8695 Assembly Guide

### **Introduction**

SLS line array rigging is designed to provide a quick method of flying and shaping line arrays. This Guide serves as an overview and provides useful hints regarding array construction. Please read in its entirety before assembling any rigging.

### **Safety Responsibilities and Liability**

All information in this guide is meant only for the purpose of rigging below the SLS supplied Rigging Frame. All other rigging is considered part of the venue and/or end-user supplied equipment and is not addressed in this guide. SLS assumes that a working knowledge of accepted rigging practices and safety will be applied to all rigging materials and practices employed. This guide is not a comprehensive source for rigging in general. The user must assume all responsibility for the appropriate use of SLS supplied rigging hardware and follow at a minimum all applicable laws and regulations in force for each venue.

The weakest component determines the safety of the entire rigging assembly. Prior to flying the array, always inspect all hardware components for wear, deformations, corrosion and missing or damaged parts. Also inspect the venue attachment points for wear and confirm that the points are suitably load rated for the suspended array.

No information contained in this guide is intended as a warranty on the part of SLS. Anyone using this information assumes all liability arising from its use. Product abuse, use of the product not in accordance with SLS instructions or use in an application which the product has not been designed for is not covered under any SLS warranty nor is SLS liable for any loss or damage.

Users in other countries should not assume that local regulations are based upon North American practices. Users should consult with local regulatory authorities for specific codes and/or guidelines.

### **Replacement Parts**

All defective components should be replaced with an SLS approved part. Contact the factory directly at (417) 883-4549 to obtain approved replacement parts. SLS is not responsible for problems caused by using non SLS supplied parts for the SLS supplied portion of the rigging.



## LS8695AX / PLS8695 Assembly Guide (1 of 5)

### FT8695 attachment:

Lay the speaker on a surface to provide a comfortable working height or alternately stand the speaker upright.

Remove the flat-head bolts from the two bottom position side panels and attach the two FT-LS8695 feet as shown with the new longer bolts provided with the kit.

Stand speaker upright (if assembling horizontally)

Adjust the leveling feet to stabilize the assembly.

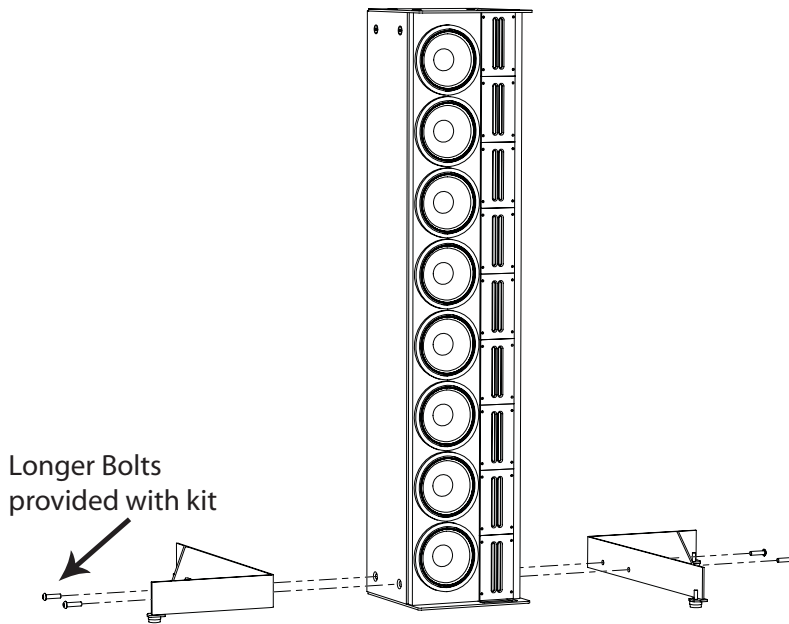
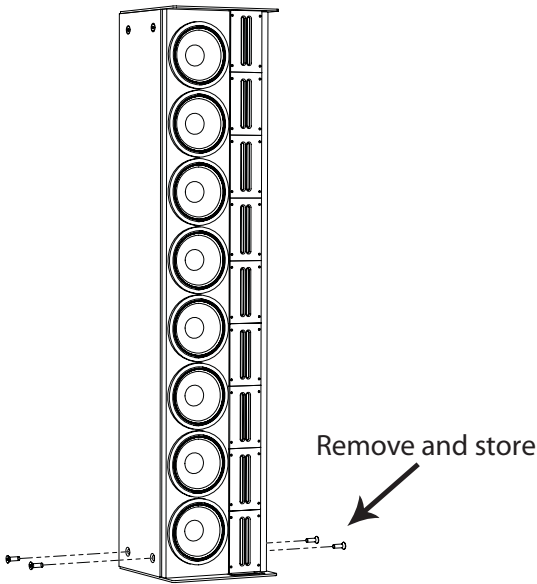

 **Note!**

The FT8695 stabilizing kit is only rated for two LS8695 series units stacked on top of each other with no other support.

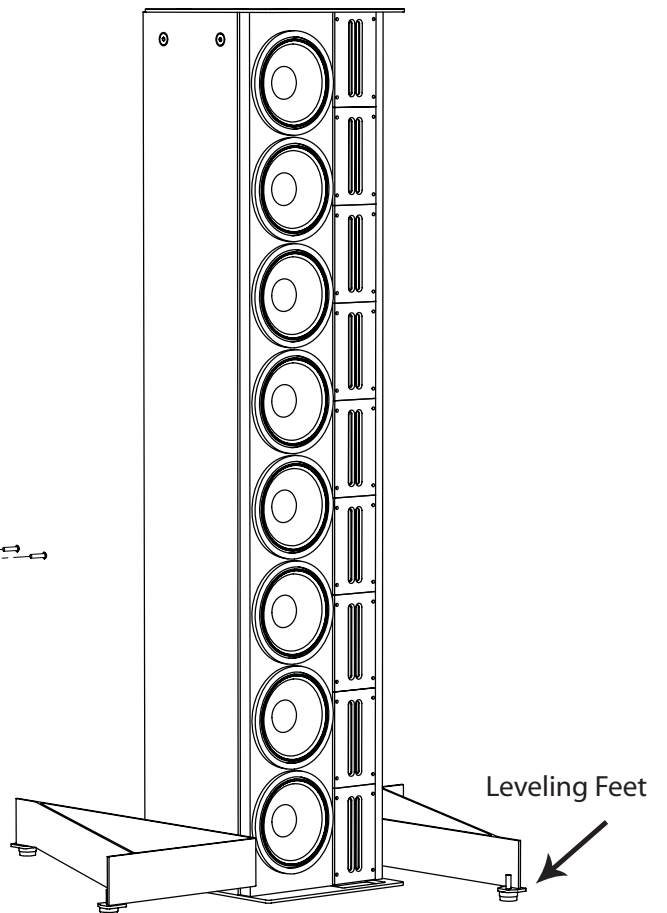



**SUPERIOR LISTENING SYSTEMS**  
AUDIO CLARITY REDEFINED

## LS8695AX / PLS8695 Assembly Guide (2 of 5)

### Stacking LS8695-Series for Portable Use:

Attach the FT8695 kit to the bottom LS8695 as previously shown.

Remove flat-head bolts from the upper sides of the speaker, and attach the MP8695 plates as shown using the new hardware included in the kit (leave bolts loose until upper speaker is in place).

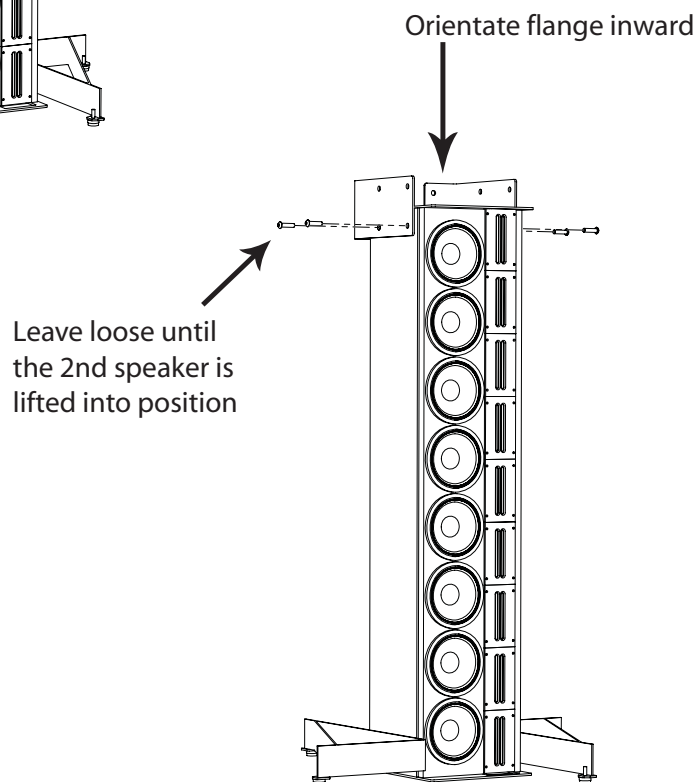
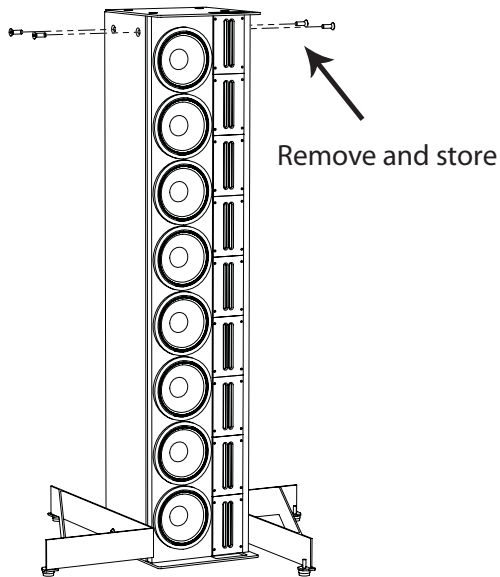



## LS8695AX / PLS8695 Assembly Guide (3 of 5)

### Stacking LS8695-Series for Portable Use (Continued):

Using two people, lift the second cabinet horizontally until the back edge is resting on the first (upright) speaker. Lift (rotate) into place while preventing movement of either the upright speaker or the lower edge of the upper speaker.

Align and attach upper speaker to MP8695 using the longer bolts and secure all hardware.

*\* An alternate assembly method can be used by laying down the two LS8695s, attaching them together using the MP8695 kit, carefully rotating the entire assembly upright and then attaching the FT8695 to the bottom cabinet.*

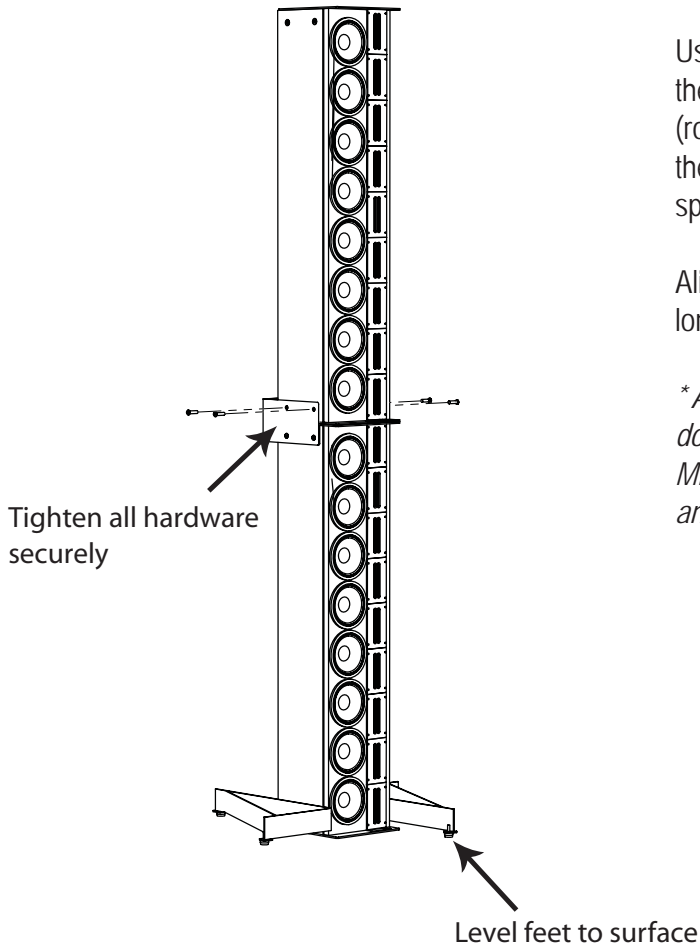

 **Note!**  
The FT8695 stabilizing kit is only rated for two LS8695 series units stacked on top of each other with no other support.

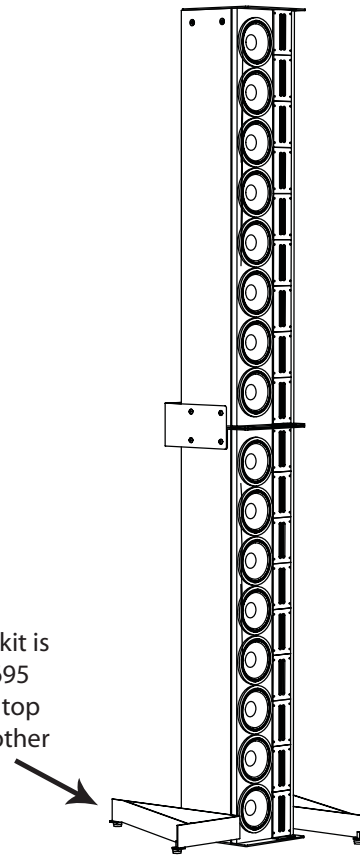



## LS8695AX / PLS8695 Assembly Guide (4 of 5)

### Single Unit Permanent Installation:

Remove the flat-head bolts from the upper and lower sides of the speaker.

Carefully measure and mount the MP8695 brackets on the wall so that the speaker attachment holes used are exactly 51.78" apart top to bottom. Place the mounting flanges inward (outwards may also be used).

Secure the speaker to the MP8695s using the supplied longer bolts as shown so that the mounting plates do not protrude above or below.

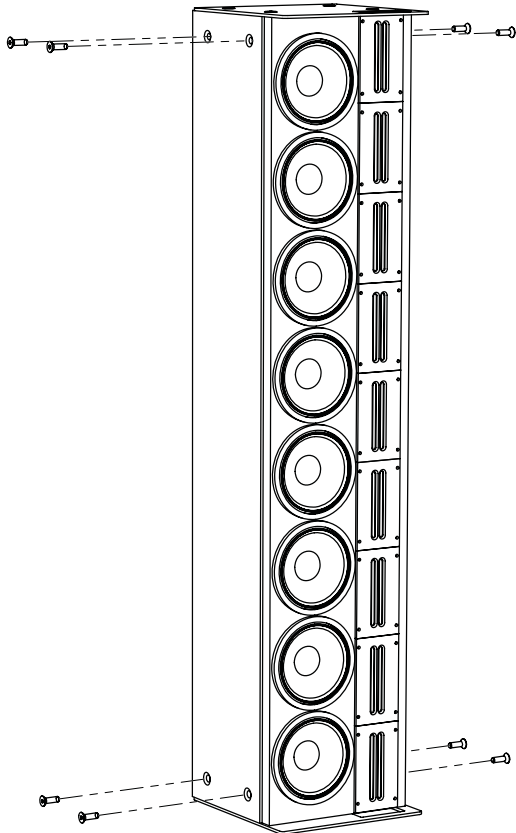

 **Note!**

Shims may be used between the upper MP8695 plates and the mounting surface to achieve small down angles of 1 to 2 degrees typical in installations using the LS8695 Series.

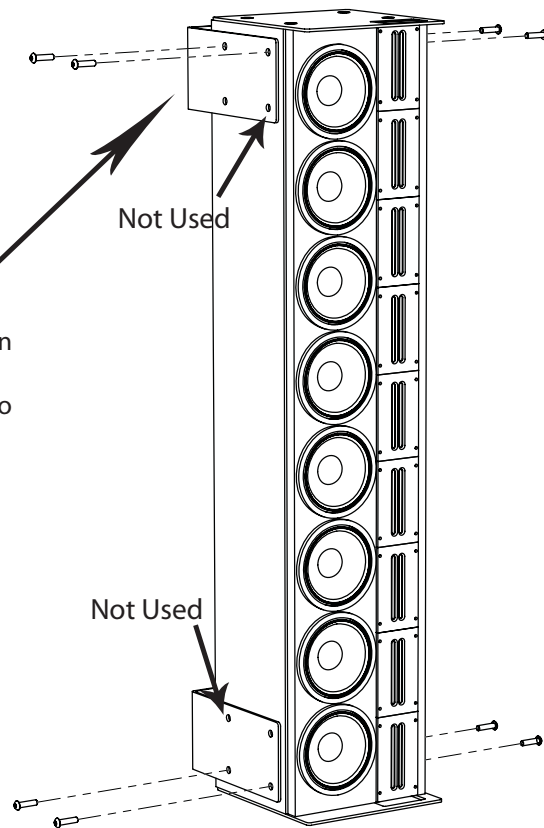



**SUPERIOR LISTENING SYSTEMS**  
AUDIO CLARITY REDEFINED

## LS8695AX / PLS8695 Assembly Guide (5 of 5)

### Multiple Units in a Permanent Installation:

Remove the flat-head bolts from the upper and lower sides of all the speakers.

Carefully measure and mount the MP8695 brackets on the wall so that the speaker attachment holes used are spaced 51.78" apart. Place the mounting flanges inwards (outwards may also be used).

Starting from the bottom, secure the first LS8695 to the brackets.

Using two people, lift the second cabinet until the front edge is resting on the top of the bottom speaker. Carefully lift (rotate) into place and secure top and bottom.

Continue as needed until the array is complete.

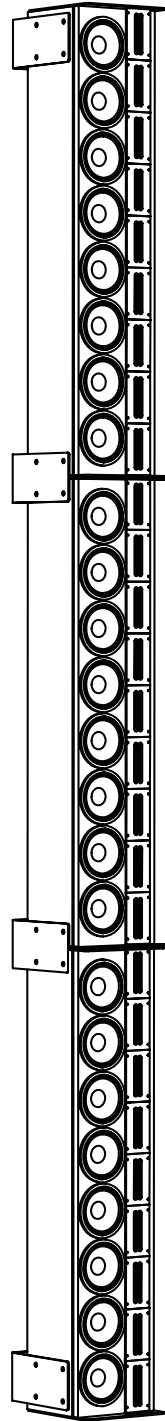



## System Specifications

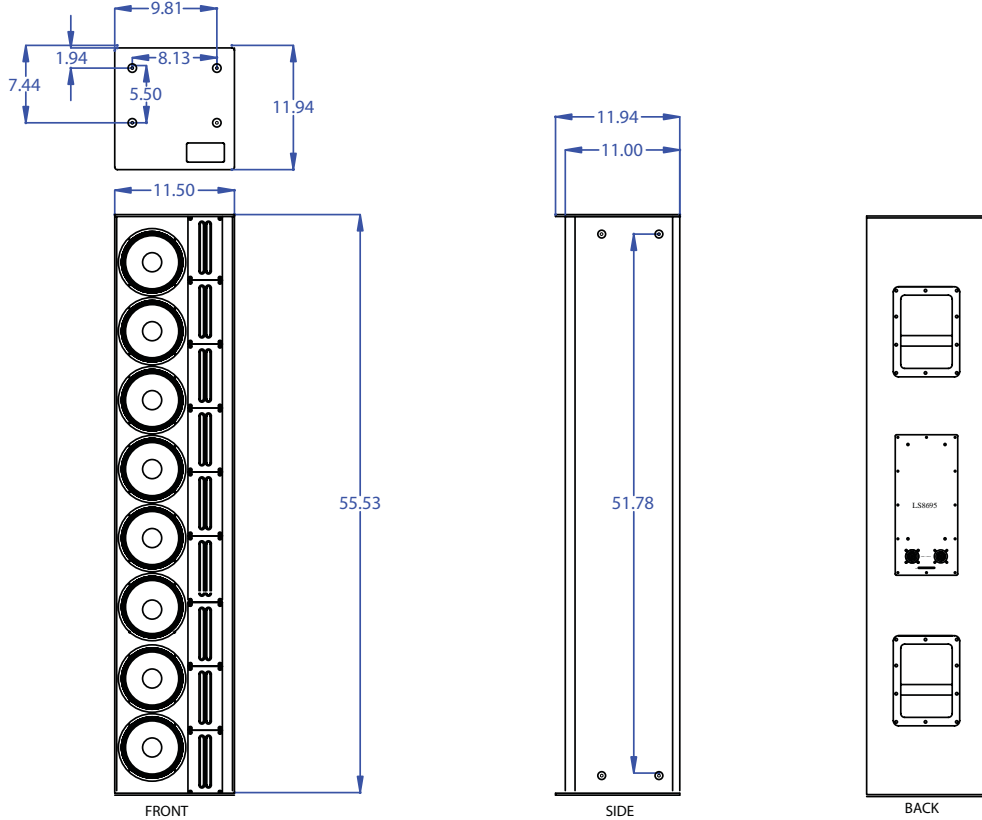

### LS8695AX

Product Specifications	
Operating Range	80 – 20,000Hz
Sensitivity <sup>1</sup> (1W/1m)	High Freq. 105dB
	Low Freq. 100dB
Horizontal Coverage Angle <sup>2</sup> -6dB	120 Degrees
Vertical Coverage Angle	Defined by height of the array
Power Handling <sup>3</sup>	High Freq. 400 Watts RMS
	Low Freq. 800 Watts RMS
Max SPL(calculated) @ 1 Meter	High Freq. 131dB Cont. / 137dB Peak <sup>4</sup>
	Low Freq. 126dB Cont. / 132dB Peak
Recommended Amp Power for Max Output	
High Freq.	800 Watts
Low Freq.	1600 Watts
Nominal Impedance	High Freq. 4 Ohms
	Low Freq. 4 Ohms
Transducers – High Freq.	9 x PRD500 Ribbons
	Low Freq. 8 x 6.5 Woofers
Input	
NL4 x 2	
Pair 1 = LF Pair 2 = HF	
Dimensions	55.5" (141cm)H
	11.5" (29.2cm)W
	12" (30.5cm)D
Enclosure	13 ply Baltic Birch
Weight	110lbs (50kg)
Rigging	16 points (4 top, 4 bottom, 4 each side) 3/8" threaded hardware
Optional Accessories	MP8695 Coupling Brackets
	FT8695 Floor Stand
	RC-LS8695 Transport Case
Finish Options	Rugged weather resistant latex paint - in black, white, or paintable natural birch

### PLS8695

Product Specifications	
Operating Range	80 – 20,000Hz
Horizontal Coverage Angle -6dB	120 Degrees
Vertical Coverage Angle	Defined by height of the array
Input Sensitivity	1.88V RMS
Max SPL(calculated) @ 1 Meter	130dB peak
	Amplifier Power High Freq. 500 Watts
Amplifier Power Low Freq.	1000 Watts
115V AC Power Consumption	11 amps at full rated output
Crossover Frequency	1500Hz
Transducers – High Freq.	9 x PRD500 Ribbons
	Low Freq. 8 x 6.5 Woofers
Dimensions	55.5" (141cm)H
	11.5" (29.2cm)W
	12" (30.5cm)D
Weight	110lbs (50kg)
Enclosure	Rugged weather resistant latex paint - in black, white, or paintable natural birch