

---

# LS7500v2 Ribbon Line Array Modules Assembly Guide

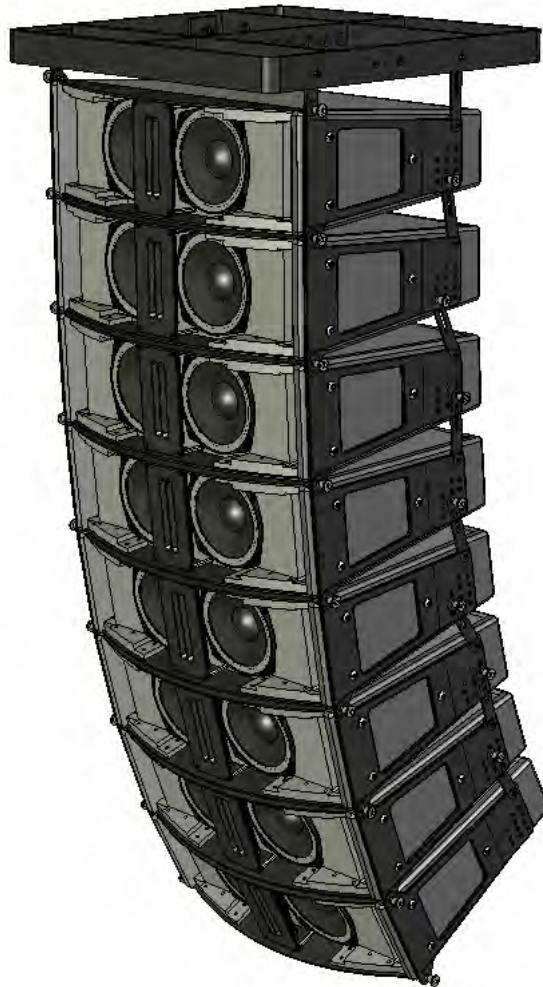

**SUPERIOR LISTENING SYSTEMS**  
AUDIO CLARITY REDEFINED



**SUPERIOR LISTENING SYSTEMS**  
AUDIO CLARITY REDEFINED

## LS7500v2 Assembly Guide

### **Introduction**

SLS line array rigging is designed to provide a quick method of flying and shaping line arrays. This Guide serves as an overview and provides useful hints regarding array construction. Please read in its entirety before assembling any rigging.

### **Safety Responsibilities and Liability**

All information in this guide is meant only for the purpose of rigging below the SLS supplied Rigging Frame. All other rigging is considered part of the venue and/or end-user supplied equipment and is not addressed in this guide. SLS assumes that a working knowledge of accepted rigging practices and safety will be applied to all rigging materials and practices employed. This guide is not a comprehensive source for rigging in general. The user must assume all responsibility for the appropriate use of SLS supplied rigging hardware and follow at a minimum all applicable laws and regulations in force for each venue.

The weakest component determines the safety of the entire rigging assembly. Prior to flying the array, always inspect all hardware components for wear, deformations, corrosion and missing or damaged parts. Also inspect the venue attachment points for wear and confirm that the points are suitably load rated for the suspended array.

No information contained in this guide is intended as a warranty on the part of SLS. Anyone using this information assumes all liability arising from its use. Product abuse, use of the product not in accordance with SLS instructions or use in an application which the product has not been designed for is not covered under any SLS warranty nor is SLS liable for any loss or damage.

Users in other countries should not assume that local regulations are based upon North American practices. Users should consult with local regulatory authorities for specific codes and/or guidelines.

### **Replacement Parts**

All defective components should be replaced with an SLS approved part. Contact the factory directly at (417) 883-4549 to obtain approved replacement parts. SLS is not responsible for problems caused by using non SLS supplied parts for the SLS supplied portion of the rigging. Page 8 of this manual contains an illustration of the available spare parts.



## LS7500v2 Assembly Guide (1 of 5)

### Assembly:

Assemble the LS7500v2 line array elements in groups of four or less by laying them face down and pinning the front two points and the two rear billets at the '0' degree position. Use the supplied black positive locking pins. Re-position the box groupings vertically.

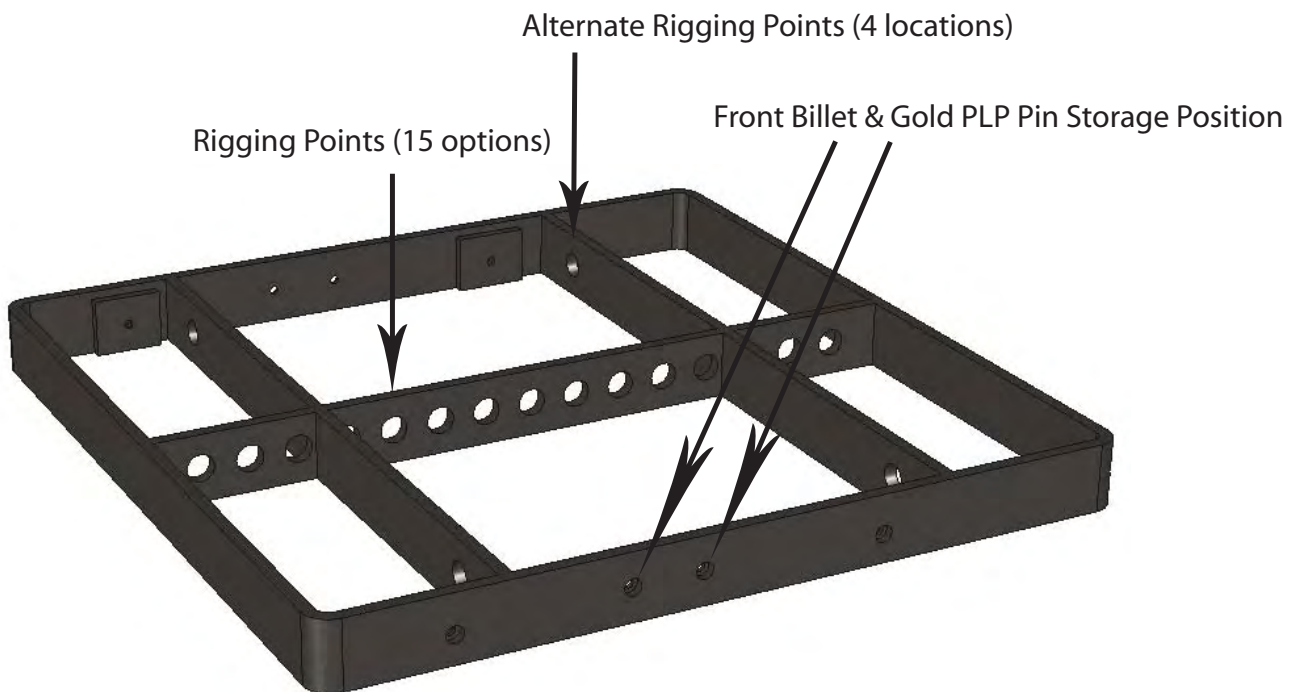
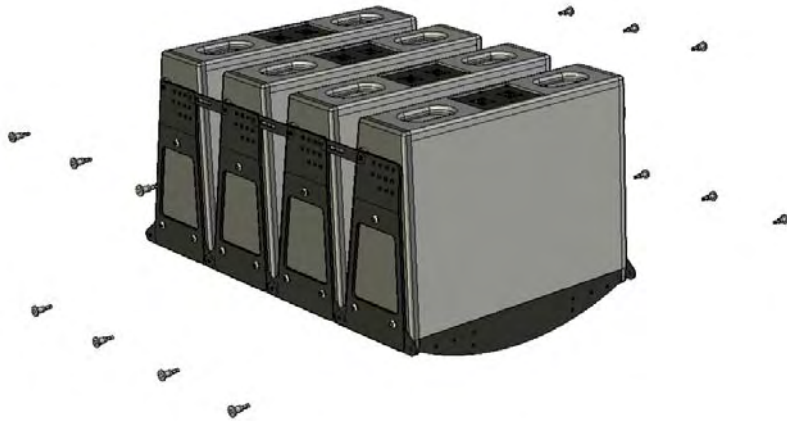



## LS7500v2 Assembly Guide (2 of 5)

The first LS7500v2 module must be level with the rigging frame. To do this, attach the rigging frame to the top LS7500v2 using the supplied (4) **GOLD** positive locking pins as shown. It is necessary to install the (2) front extension billets to make the 1st box level.

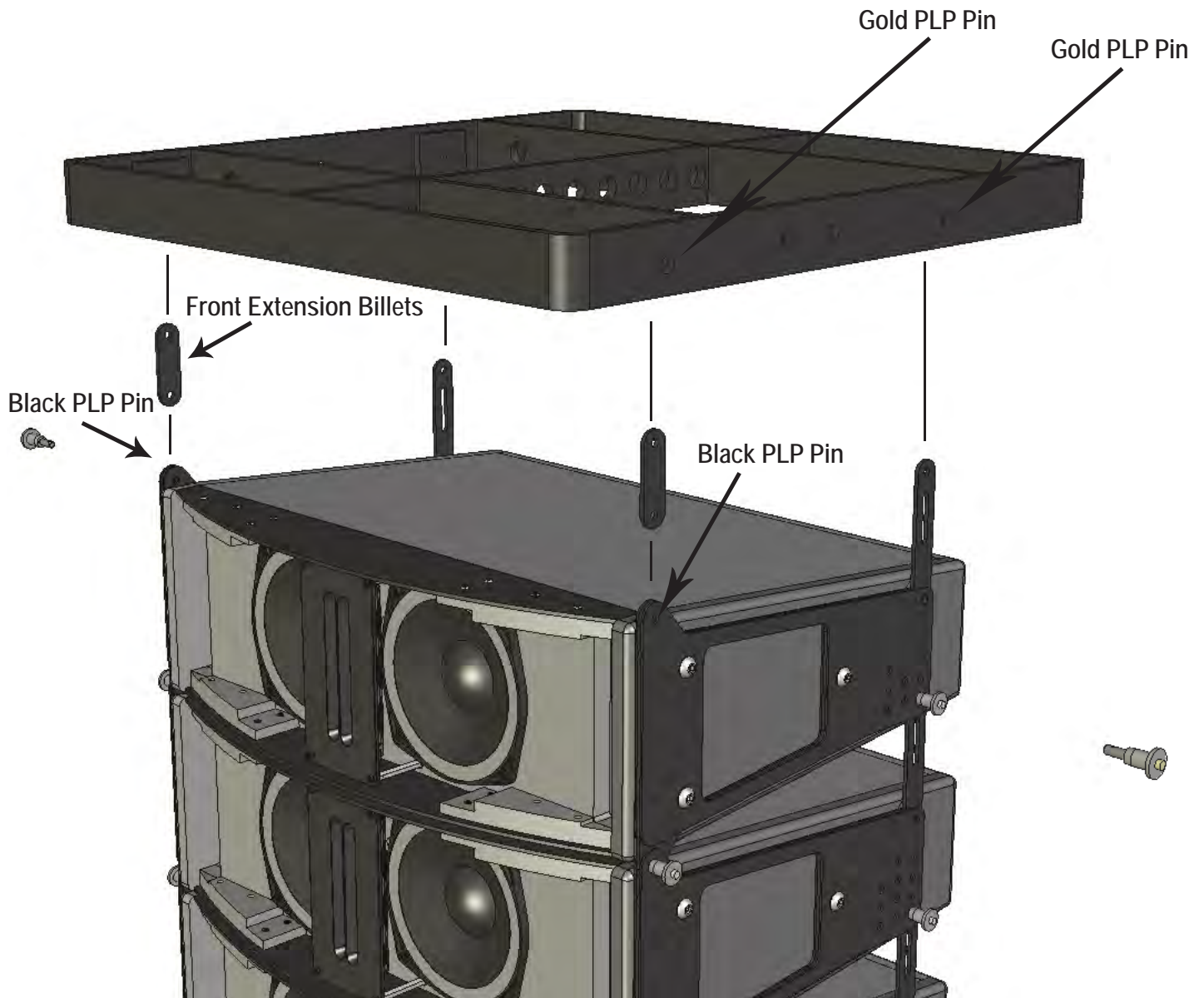



**SUPERIOR LISTENING SYSTEMS**  
AUDIO CLARITY REDEFINED

## LS7500v2 Assembly Guide (3 of 5)

Attach the Rigging Frame to your house rigging on the hole number calculated by LASS and raise the four LS7500v2's to a comfortable working height. Set the inter-element splay angles between the array elements, based on the results of your LASS model. Lift from the bottom to close the articulation angles as necessary, pinning at the appropriate angle point on each side.





## LS7500v2 Assembly Guide (4 of 5)

Further raise the array and move the 2nd group of LS7500v2 line array elements underneath the flown section. Lower the flown array and land the elements onto the ground stacked LS7500v2 group, lining up the front billets. Attach the two front pins through these front billets, then attach the two rear points through the splay angle calculated by LASS for that box (you will most likely have to further lower the flown elements to do this).

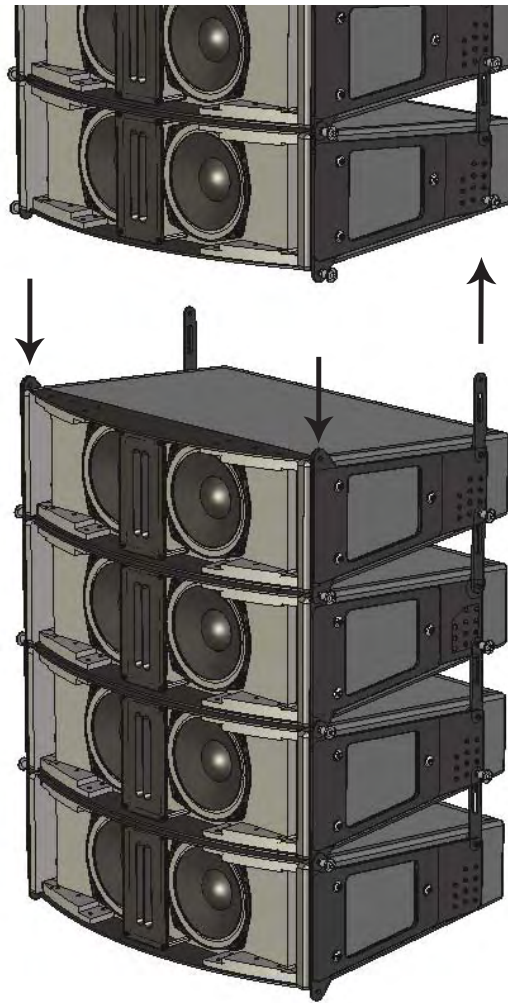



**SUPERIOR LISTENING SYSTEMS**  
AUDIO CLARITY REDEFINED

## LS7500v2 Assembly Guide (5 of 5)

Raise the rigging frame back to a comfortable working height and adjust the splay angles for all of the second block of elements. Continue as necessary until the array is complete.



 **Note!**

Do not exceed (24)  
LS7500v2 boxes per  
Rigging Frame.



## LS7500v2 System Specifications & Parts

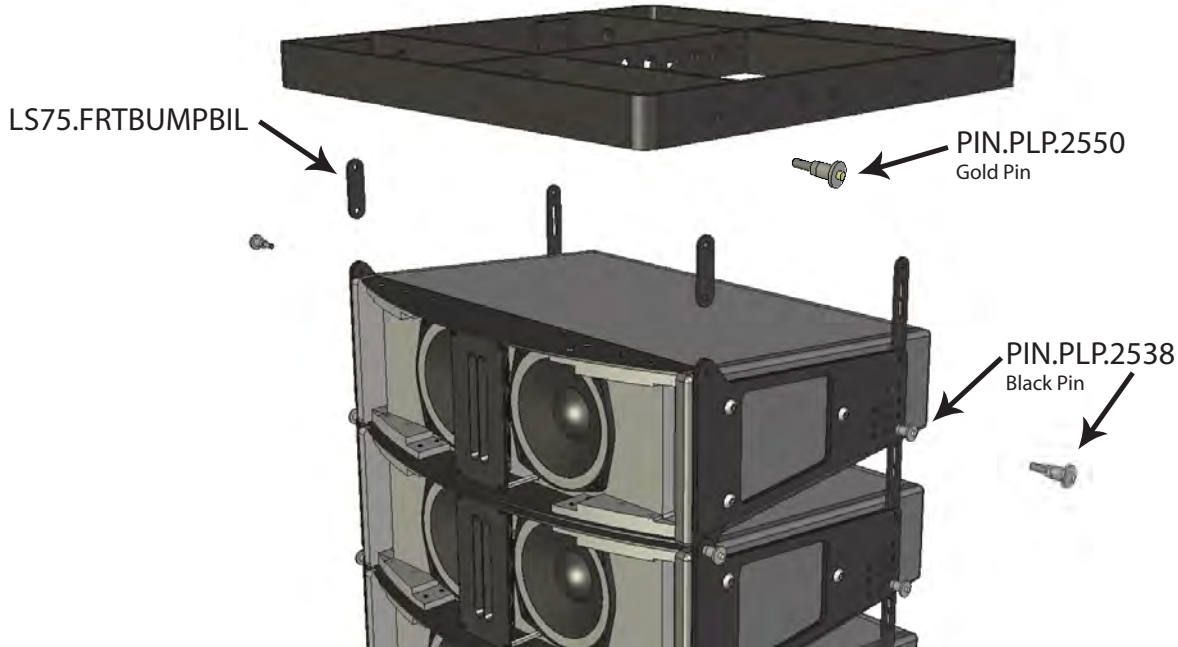

Product Specifications	
Operating Range <sup>1</sup>	80Hz - 20,000Hz
Sensitivity (1W/1M) - Low Freq. <sup>2</sup>	95dB
High Freq.	101dB
Horizontal Coverage Angle -6dB <sup>3</sup>	110 Degrees
Vertical Coverage Angle	Defined by height and configuration of the array
Power Handling - Low Freq. <sup>4</sup>	250W (45 Volts) AES/2
High Freq.	145W (32 Volts) IEC Short Term 46W (18 Volts) IEC Long Term 35W (15.6 Volts) AES/2
Recommended Amp Power for Max Output	
Low Freq.	500 Watts @ 8 ohms
High Freq.	150 Watts @ 8 ohms
Max SPL (calculated) 1 Meter - Low Freq. <sup>5</sup>	119dB Cont. / 125dB Peak
High Freq.	118dB Cont. / 123dB Peak
Nominal Impedance - Low Freq.	8 Ohms
High Freq.	7 Ohms
Crossover Frequency	DSP Settings Provided
Transducers - Low Freq.	6.5" Bass/Midrange x2
High Freq.	PRD500 Ribbon
Input	NL4 x2 (Pair 1 = LF, Pair 2 = HF) Barrier Strip on I version
Dimensions	7.22" (18.4cm) H (front side) 4.67" (11.9cm) H (rear side) 22.44" (58.4cm) W 17.91" (45.5cm) D
Enclosure	13ply Baltic Birch
Weight	38lbs (17.24kg) Shipping 47lbs (21.3kg)
Rigging	All array rigging is included
Optional Accessories	RLA/4-BB - Rigging Frame <sup>6</sup> RC.RLA/4 - Road case for (4) LS7500 RC.RLA/4-6 - Road case for (6) LS7500
Finish Options	Black Latex White Latex (w/ white rigging) Paintable Natural Finish (w/ black rigging)

1. LF at -10dB, HF -6dB at 40kHz on-axis however response above 20kHz is limited by air absorption and DSP sampling rates in typical PA applications.
2. Full bandwidth pink noise is applied and amplified to a level and measured at the loudspeaker terminals - corresponding to 1 Watt as referenced to the loudspeakers nominal impedance. SPL is measured in an anechoic environment in the loudspeakers far field. Data is extrapolated to 1 Meters distance from the loudspeaker.
3. Averaged from 1000Hz to 10kHz
4. AES established with ambient temperature at 22C in accordance with AES/2-1984 standard. IEC stated in RMS voltage according to IEC 268-5
5. Typical SPL for one box only, for array SPL refer to LASS calculations. Ribbon SPL calculated from IEC long term and short term
6. Rigging Frame weight is 30lbs