



Product Technical Data Sheet
Model CS-MH2806

Description

The CS-MH2806 is a mid/high bi-amp cinema loudspeaker. Its primary application is use as a full range screen channel with the CSB215 Mid-Bass enclosure in large theaters.

The CS-MH2806 high frequency section features a high performance PRD1000 planar ribbon transducer designed and manufactured by SLS Loudspeakers. The unique design and properties of the planar ribbon driver allows for a very clear delivery and transient accuracy even at the limits of its performance.

The midrange section uses dual 8" drivers mounted on a wave guide to match the dispersion pattern of the PRD1000 ribbon. The drivers feature a large vented magnet structure with a flux demodulation ring magnet system which divides by 3 the harmonic distortion in the lower frequency domain and reduces the inductance modulation by 50%, leading to a dynamic and stable sound quality.

Key Features:

- PRD1000 ribbon high frequency line driver delivers unsurpassed sound quality
- Horn Loaded midrange with high quality dual 8" drivers for increased clarity and punch.
- Open and clear sound at high SPL due to advanced transducer technology in all bandwidth sections
- 80 x 40 degree dispersion pattern
- Included U-Bracket for easy installation and aiming



Product Specifications	
Operating Range	200Hz - 30,000Hz
Sensitivity (1W/1M) - Mid Freq. ¹	102dB
High Freq.	107dB
Horizontal Coverage Angle -6dB ²	80 Degrees
Vertical Coverage Angle -6dB ²	40 Degrees
Power Handling - Mid Freq. ³	500W (64 Volts) AES/2
High Freq.	385W (50 Volts) IEC Short Term 104W (26 Volts) IEC Long Term 60W (20 Volts) AES/2
Recommended Amp Power for Max Output	
Mid Freq.	1000 Watts @ 8 ohms
High Freq.	400 Watts @ 8 ohms
Max SPL (calculated) 1 Meter - Mid Freq.	129dB Cont. / 135dB Peak
High Freq. ⁴	127dB Cont. / 133dB Peak
Nominal Impedance - Low Freq.	8 Ohms
High Freq.	6.5 Ohms
Crossover Frequency	DSP Settings Provided
Transducers - Mid Freq.	8" Midrange x 2
High Freq.	PRD1000 Ribbon
Input	Barrier Strip
Dimensions	33.75" (85.7cm) H 18" (45.7cm) W 16" (40.6cm) D
Enclosure	MDF
Weight	98lbs (44.45kg) Shipping 110lbs (50kg)
Rigging	U-Bracket for attachment to CS-B215
Finish	Flat Black Latex

Applications

Developed for high performance cinema applications where the highest quality and intelligibility of sound is required

- Behind Screen LCR

1. Full bandwidth pink noise is applied and amplified to a level and measured at the loudspeaker terminals - corresponding to 1 Watt as referenced to the loudspeakers nominal impedance. SPL is measured in an anechoic environment in the loudspeakers far field. Data is extrapolated to 1 Meters distance from the loudspeaker.
2. Averaged from 500Hz to 8kHz
3. AES established with ambient temperature at 22C in accordance with AES/2-1984 standard. IEC stated in RMS voltage according to IEC 268-5
4. Ribbon SPL calculated from IEC long term and short term



CS-MH2806 Drawings

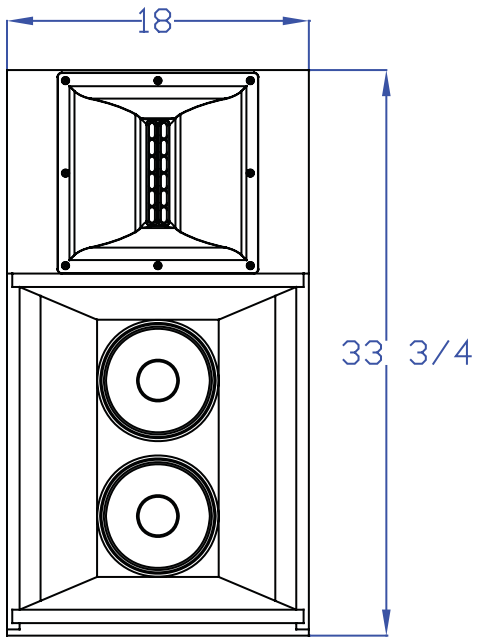

FRONT

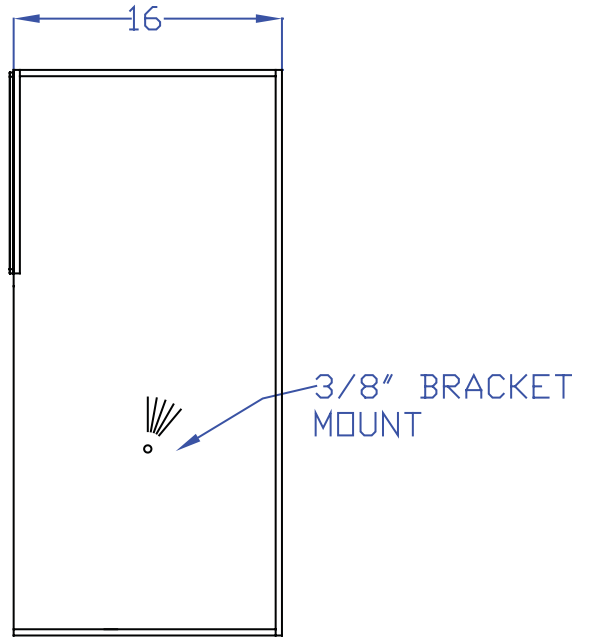

SIDE

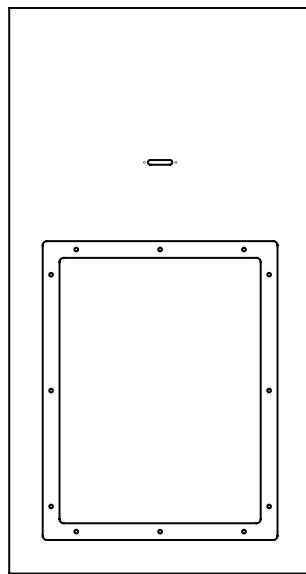

BACK