CDA300

Owners Manual



SUPERIOR LISTENING SYSTEMS
AUDIO CLARITY REDEFINED



SUPERIOR LISTENING SYSTEMS
AUDIO CLARITY REDEFINED

CDA300 Owners Manual

Introduction

Thank you for your purchase of the CDA300. It is our goal to make the installation and use of your speaker as simple as possible. Please read this manual for helpful hints before using or mounting the CDA300.

Safety Responsibilities and Liability

All information in this guide is meant only for the purpose of using the SLS supplied mounting equipment. All other rigging and/or structure support including wall securing hardware is considered part of the venue and/or end-user supplied equipment and is not addressed in this guide. SLS assumes that a working knowledge of accepted rigging practices and safety will be applied to all rigging materials and practices employed. This guide is not a comprehensive source for rigging in general. The user must assume all responsibility for the appropriate use of SLS supplied rigging hardware and follow at a minimum all applicable laws and regulations in force for each venue.

The weakest component determines the safety of the entire rigging assembly. Prior to securing the speaker, always inspect all hardware components for wear, deformations, corrosion and missing or damaged parts. Also confirm that the venue attachment points are suitably load rated for the speaker.

No information contained in this guide is intended as a warranty on the part of SLS. Anyone using this information assumes all liability arising from its use. Product abuse, use of the product not in accordance with SLS instructions or use in an application which the product has not been designed for is not covered under any SLS warranty nor is SLS liable for any loss or damage.

Users in other countries should not assume that local regulations are based upon North American practices. Users should consult with local regulatory authorities for specific codes and/or guidelines.

Replacement Parts

All defective components should be replaced with an SLS approved part. Contact the factory directly at (417) 883-4549 to obtain approved replacement parts. SLS is not responsible for problems caused by using non SLS supplied parts.



Using the Supplied Rigging Attachment Points

Every CDA300 is supplied with the hardware for providing three rigging attachment points. If the CDA300 is going to be flown using this hardware, please attach the pieces as shown in the rendering below. Each rigging hole inside diameter is .41" which will allow the use of either a 3/8" or 10mm shackle.

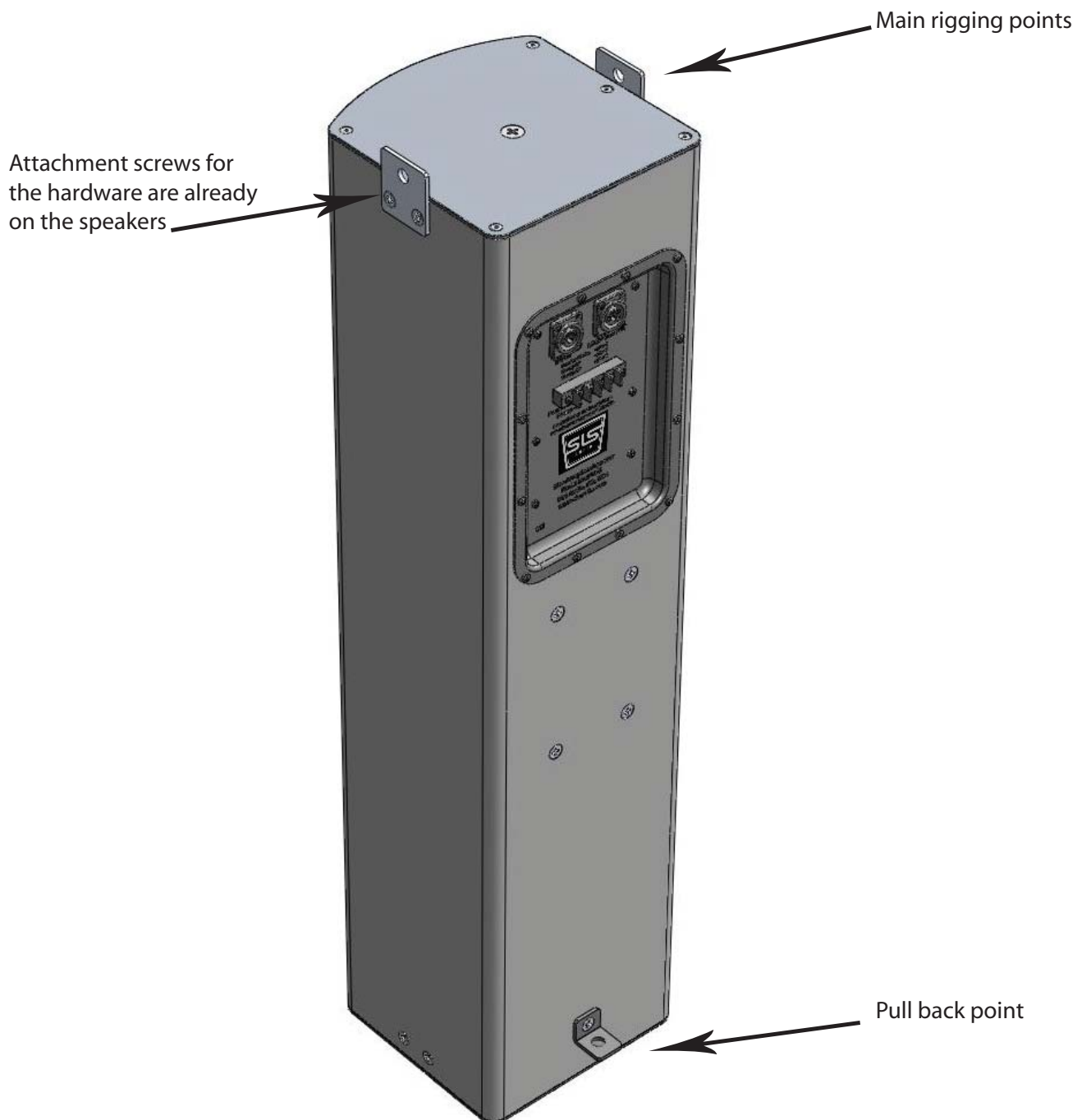



Using the Optional U-Bracket

If the CDA300 is to be mounted on a wall or flown horizontally, the optional u-bracket should be used. Please attach as shown in the below rendering.

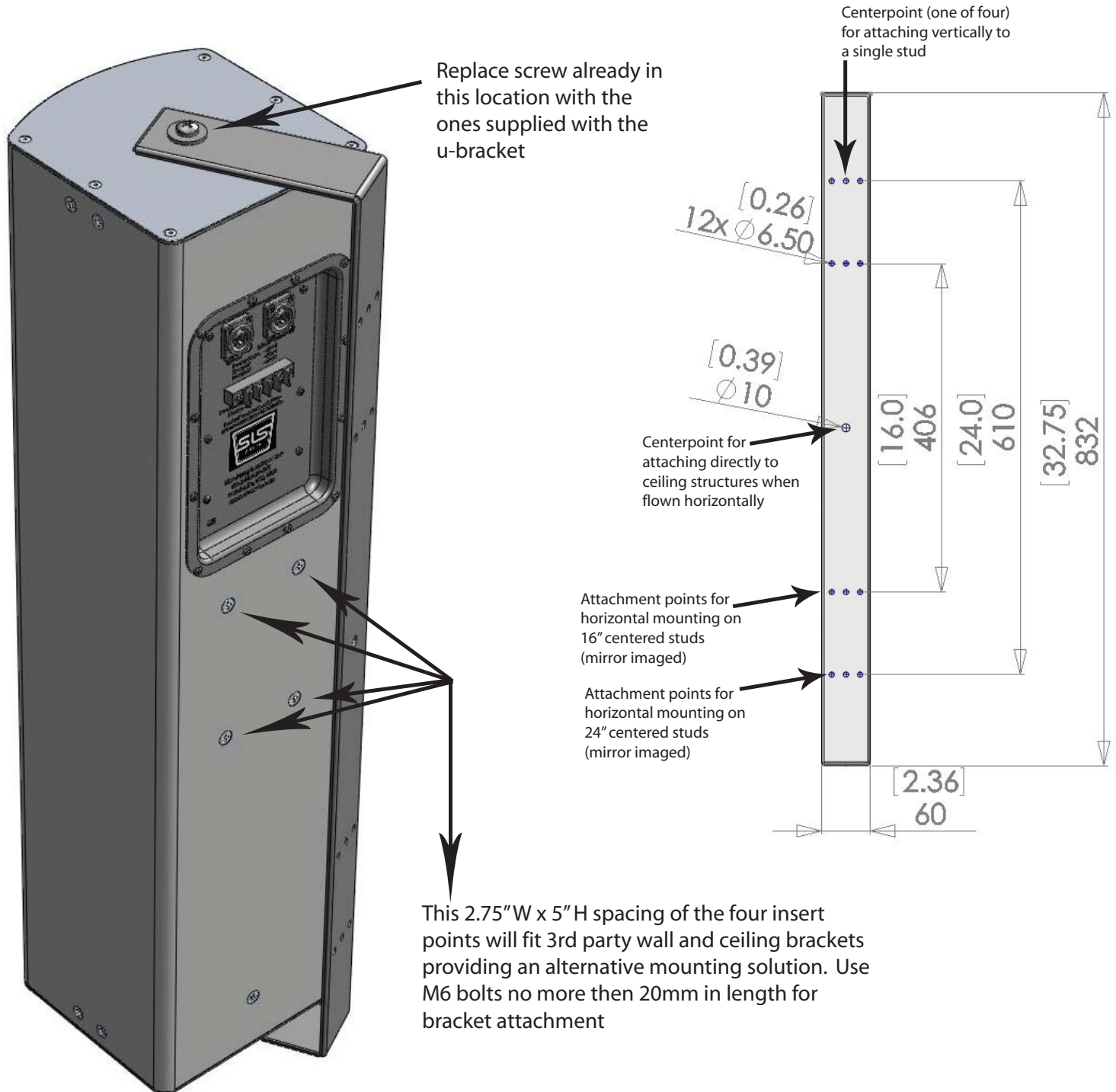



SUPERIOR LISTENING SYSTEMS
AUDIO CLARITY REDEFINED

Using the Optional Pole Mount Bracket

The optional pole mount bracket should be attached as shown in the below rendering. This bracket is also required if the CDA300 is to be used with it's companion subwoofer, the SP15.

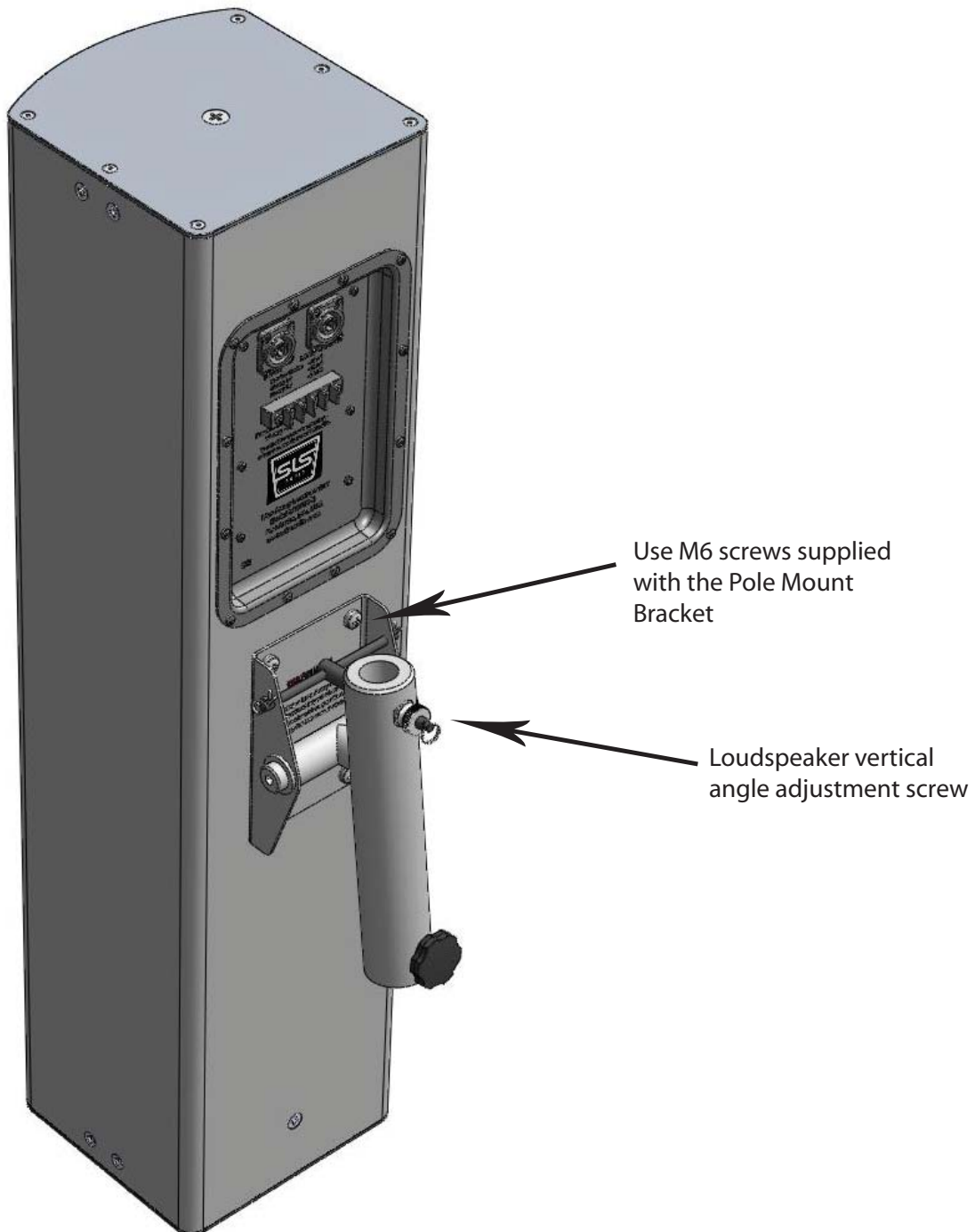



CDA300 Specifications

Product Specifications	
Operating Range ¹	62Hz - 20,000Hz
Sensitivity (1W/1M) ²	91dB
Horizontal Coverage Angle -6dB ³	90 Degrees
Vertical Coverage Angle -6dB ³	60 Degrees
Power Handling ⁴	300W (49 Volts) AES/2
Recommended Amp Power for Max Output	600 Watts @ 8 ohms
Max SPL (calculated) 1 Meter	116dB Cont. / 122dB Peak
Nominal Impedance	8 Ohms
Crossover Frequency	Internal Passive Custom 4-way
Transducers - Low Freq.	5.25" Woofer x6
High Freq.	PRD250 Ribbon x3
Input	NL4 and Barrier Strip
Dimensions	32.3" (82cm) H 7.5" (19cm) W 8" (20cm) D
Enclosure	Extruded Aluminum
Weight	32lbs (14.5kg) Shipping 36lbs (16.3kg)
Rigging	Included
Finish Options ⁵	Black Powdercoat Aluminum White Powdercoat Aluminum
Optional Accessories	U-bracket Pole Mount Bracket Subwoofer Extension Pole

1. LF at -10dB, HF -6dB at 40kHz on-axis however response above 20kHz is limited by air absorption and DSP sampling rates in typical PA applications.
2. Full bandwidth pink noise is applied and amplified to a level and measured at the loudspeaker terminals - corresponding to 1 Watt as referenced to the loudspeakers nominal impedance. SPL is measured in an anechoic environment in the loudspeakers far field. Data is extrapolated to 1 Meters distance from the loudspeaker.
3. Averaged from 1000Hz to 10kHz
4. AES established with ambient temperature at 22C in accordance with AES/2-1984 standard. IEC stated in RMS voltage according to IEC 268-5
5. Cabinet rated at IEC529-IP35 and Mil Spec 810

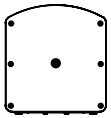

TOP

7.50
[190.5mm]

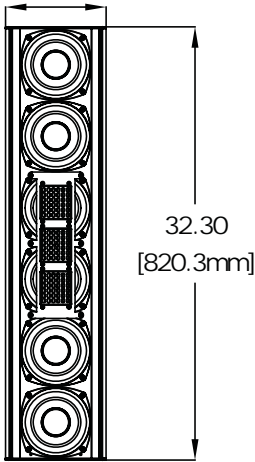

FRONT

7.97
[202.4mm]

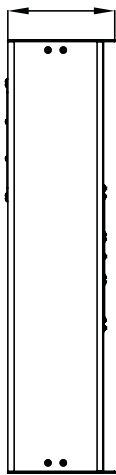

SIDE

M6 x 20 INSERT
4 PLACES

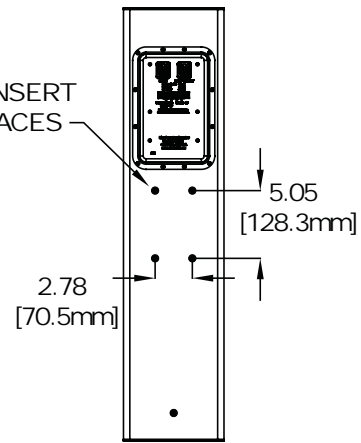

BACK

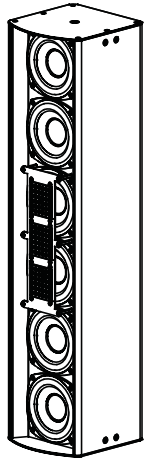



CDA300 Processor Settings

High Pass Filter

	Frequency	Slope
w/o subwoofer - HPF	60Hz	24dB Oct. Butterworth
w/SP15 subwoofer - HPF	80Hz	24dB Oct. Butterworth

Equalization

Frequency	BW*	Q	Level
1,375Hz	.125	11.54	+4dB
2,000Hz	.25	5.76	-3dB

Limiting

RMS Voltage

See Application Note
"Setting System Limiters"

49 Volts, 16 msec attack, 256 msec release, 100:1 ratio (recommended predictive peak stop @ 98 Volts or amp clipping)

* BW Disclaimer

Different DSP processor manufactures are not consistent in their implementation of digital parametric EQs. **The SLS recommended filters will not be replicated by all DSP devices.** If the DSP device that is used continuously varies the Q value of the filter depending on the +/- dB level, the DSP will not match our settings. (Most of these devices do not allow filter Q to be shown at all.)