



Product Technical Data Sheet
Model 8290Tv2-I

Description

The 8290Tv2-I is a full-range passive high quality dual 8" two-way design. It serves as a installation box that offers a small format with maximum SPL.

The 8290Tv2-I high frequency section features a high performance PRD500 planar ribbon transducer designed and manufactured by SLS Loudspeakers. The unique design and properties of the planar ribbon driver allows for a very clear delivery and transient accuracy even at the limits of its performance. The PRD500 is contained within a 90 degree die cast aluminum waveguide.

The 8290Tv2-I contains an improved woofer with greater power handling resulting in a 3dB louder design over the original 8290T-I.

The crossover contains an unique 2 1/2 way audiophile grade network delivering smooth response and consistent polar patterns throughout the crossover regions. The 8290Tv2-I therefore closely matches the midrange and high frequency character of the 8190v2T-I so the two models can be interchanged as needed in a design.

Key Features:

- PRD500 ribbon high frequency driver delivers unsurpassed sound quality
- Integrated Rigging Points
- Rotatable Ribbon
- 90 degree wide horizontal coverage
- 2 1/2 way passive crossover
- ¾" 13 ply Baltic Birch cabinet



Product Specifications	
Operating Range ¹	60Hz - 20,000Hz
Sensitivity (1W/1M) ²	95dB
Horizontal Coverage Angle -6dB ³	90 Degrees
Vertical Coverage Angle -6dB ³	30 Degrees
Power Handling ⁴	450W RMS (42 Volts) AES/2
Max SPL (calculated) 1 Meter	122dB Cont. / 128dB Peak
Recommended Amp Power for Max Output	900 Watts @ 4 ohms
Nominal Impedance	4 Ohms
Crossover	Internal Passive 2 1/2 Way
Transducers - Low Freq.	8" Bass Only
Low/Mid Freq.	8" Bass/Midrange
High Freq.	PRD500 Ribbon
Input	Barrier Strip
Dimensions	29.75" (75.6cm) H 12" (30.5cm) W 13.5" (34.4cm) D
Enclosure	13ply Baltic Birch
Weight	43lbs (19.5kg) Shipping 51lbs (23.1kg)
Rigging	14 Points 3/8" / 16 Threaded Inserts
Finish Options	Black Latex White Latex Paintable Natural Finish

Applications

Developed for a wide range of professional applications where the highest quality and intelligibility of sound is required

- Choir Monitoring
- Installation spot fills

1. LF at -10dB, HF -6dB at 40kHz on-axis however response above 20kHz is limited by air absorption and DSP sampling rates in typical PA applications.
 2. Full bandwidth pink noise is applied and amplified to a level and measured at the loudspeaker terminals - corresponding to 1 Watt as referenced to the loudspeakers nominal impedance. SPL is measured in an anechoic environment in the loudspeakers far field. Data is extrapolated to 1 Meters distance from the loudspeaker.
 3. Averaged from 1000Hz to 10kHz
 4. AES established with ambient temperature at 22C in accordance with AES/2-1984 standard. IEC stated in RMS voltage according to IEC 268-5



8290Tv2-I Drawings

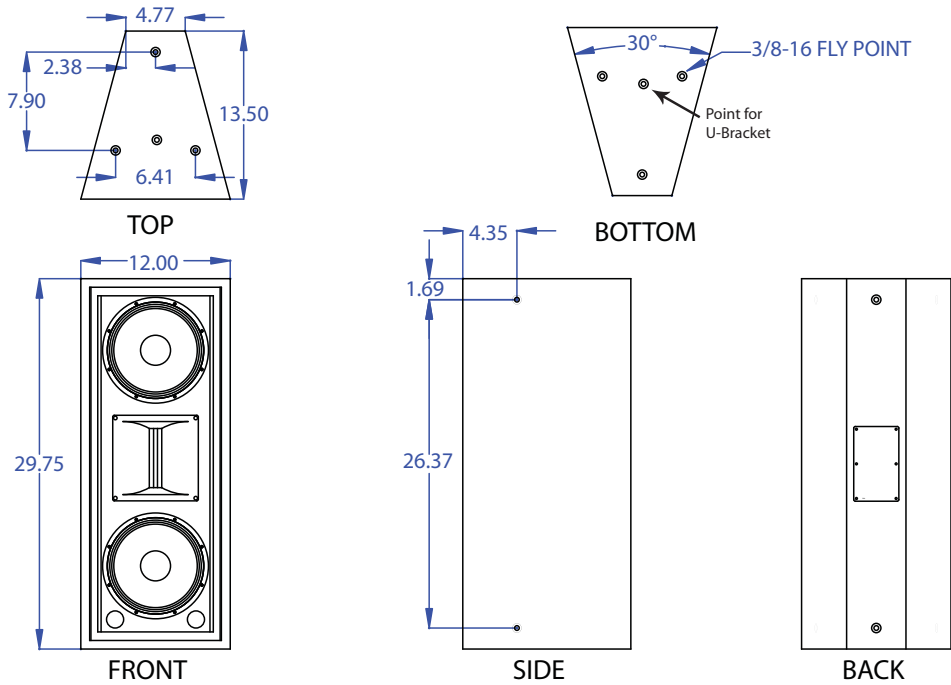

Polars

Horizontal Axis

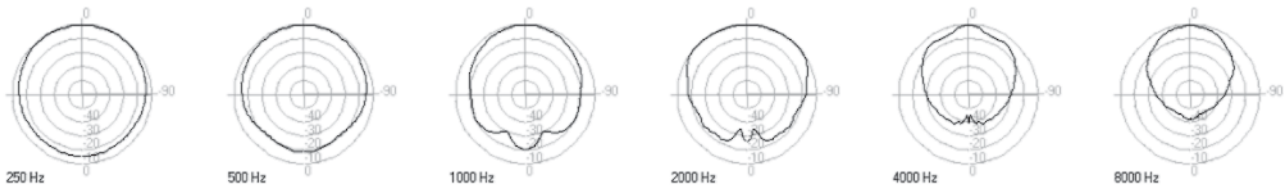

Vertical Axis

